

# Besam Curved Sliding Door

## Besam CMD

ASSA ABLOY

ASSA ABLOY Entrance Systems

The global leader in door opening solutions



The Besam Curved sliding door produces an impressive and elegant entrance with depth in addition to width and height

### **The impressive and functional entrance**

Besam CMD sliding door makes it possible to design the entrance in three dimensions, with depth in addition to the normal width and height. This gives the entrance an elegant and decorative appearance whilst it remains extremely functional. The Besam CMD curved sliding door system (bi-parting with two leaves) can be tailored to meet different customer requirements within the stated parameters.

A curved sliding door gives a wider opening than a flat sliding door and at the same time provides an impressive and enticing entrance. The discreet form and compact dimensions allow the Besam CMD to be a part of the architectural design. The Besam CMD, like all Besam door systems, is designed with regard to place the safety of the user as of the highest importance.

### **Technical specifications**

Power supply	120 V AC -10 % to 240 V AC +10 %; 50/60 Hz
Power consumption	max. 250 W
Recommended max. door weight	100 kg/door leaf
Opening and closing speed	variable up to 1.4 m/s
Hold open time	0 – 60 s
Ambient temperature	-20°C to +50°C
Relative humidity (non-condensing)	5% to 85%

### **Emergency**

Besam CMD can either be combined with a mechanical emergency unit that automatically opens the doors – or an electronic emergency unit that automatically opens or closes the doors – in the event of a power failure. The Besam CMD can also be interfaced with fire alarms or smoke detectors.

### **Self-monitoring**

The operator microprocessor has an integral self-monitoring device which detects any interference or faulty signals in door operation and takes necessary measures to ensure a safe operation.

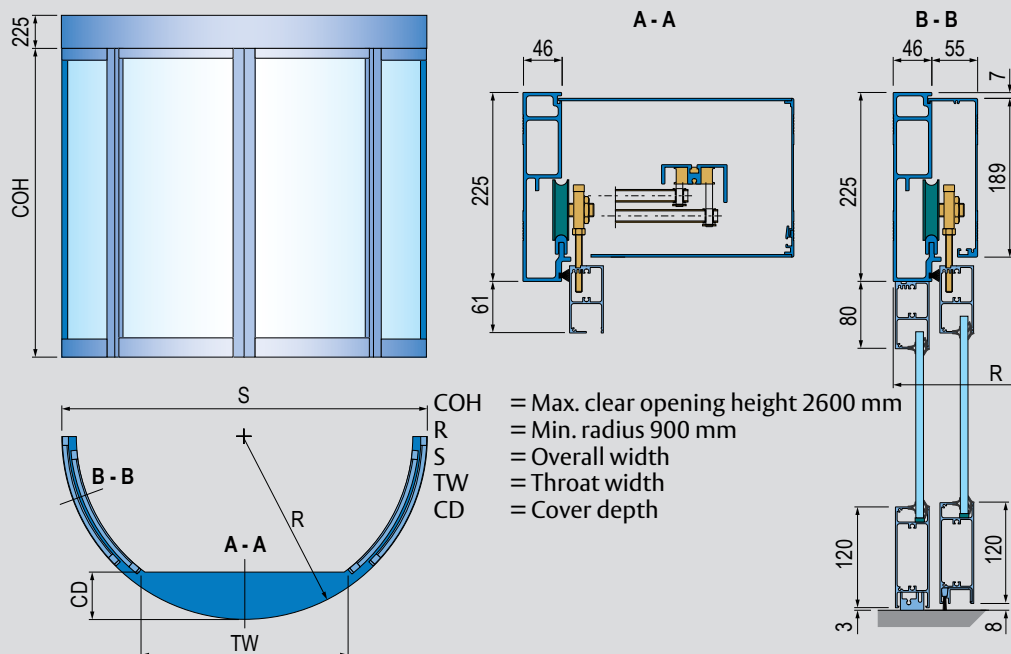

## Design

The drive unit, control unit, transmission – and optional emergency unit and electromechanical locking device – are all assembled in a compact drive module. The drive unit transmits movement to the door leaves by means of a tooth belt. The drive module is mounted inside a support beam and can be equipped with integrated cover. The door leaves can be adjusted height-, length- and depth-wise. Plastic rollers and a sliding track made of aluminium give exceptionally smooth and silent operation. Besam CMD can be delivered as operator only (Besam UniSlide C) or complete with covers, door leaves and fixed screens. It is available with external or internal doors.

## Standard equipment

Operator including

- Drive unit with transmission
- Electronic control unit with plug-in connections and power supply
- Traffic-controlled opening width
- Synchronizing of two operators

Door leaves made from aluminium profiles

Outer walls made from aluminium profiles

Glass: 4+4 mm clear laminated (Other types available)

Presence detection safety sensor placed vertically and flush mounted above the entrance

## Accessories and Options

Surface treatment

- Clear anodized aluminium (other anodizing optional)
- Paint finished in colour RAL (paint finishes according to RAL chart optional)

Door adaptor for doors made by others

Programme selectors

Electronic emergency opening or closing unit

Mechanical emergency opening unit

Emergency button

Besam approach and presence sensors

Electromechanical locking device

Interlocking between two operators

Key switch

Mechanical lock (on door leaves)

Ceiling (internal door operators only)

Dust protection roof

Water resisting cover

Spotlights

This equipment should be installed, regularly inspected, maintained and serviced by trained and authorized personnel. Preventive maintenance plans are highly recommended for a proper and safe operation. Talk to your ASSA ABLOY Entrance Systems representative to learn more about our service offering!