

Sliding Door Operator Besam SL500

ASSA ABLOY

ASSA ABLOY Entrance Systems

The global leader in
door opening solutions



The modular sliding door Besam SL500 enables upgrades and add-ons when you want to move your business forward

Sustainable entrances

You can be sure that your entrance suits your people flow as well as your environmental footprint. To make your entrance more sustainable we can offer you different solutions as: additional sealing (Besam TightSeal), sustainable drive mode, intelligent opening width depending on traffic, inner- and outer door air locking, and timer settings and more.

Safety first

To permit safe passage between closing doors, the doors go into reverse mode if an obstruction is detected, and then start moving again slowly to check if the obstruction has cleared. If an obstruction is detected during opening or between opening doors and surrounding walls or interior fittings, the doors immediately stop and then close after a time delay. The speed and force of the doors can be customized to optimize safety. For optimum safety and user convenience, use a monitored ASSA ABLOY presence-detection system.

Technical specifications

Operator dimensions	150 mm x 123 mm (height x depth)
Power supply	100-240 VAC \pm 10% 50/60 Hz
Power consumption	max. 250 W
Recommended maximum door weight	
Besam SL500-2 without break-out	200 kg/door leaf
Besam SL500-2 with break-out	100 kg/door leaf
Besam SL500-1 without break-out	240 kg
Besam SL500-1 with break-out	100 kg
Clear opening width (COW)	
Besam SL500-2	1000 – 3000 mm (bi-parting)
Besam SL500-1	800 – 3000 mm (single slide)
Contact local sales representative for other dimensions.	
Open and closing speed	up to 1.7 m/s (2 leaves) variable
Hold-open time	0 – 60 s
Ambient temperature	-20°C to +50°C
Relative humidity (non-condensing)	max. 85%

Security

Choose your security level by adding different features. Unwanted guests are not an issue for the Besam SL500 through the use of different locking devices. The operation mode selector can be set to meet your security needs during and outside business opening hours. Interlocking facilities further enhance the security level.

Service and maintenance for your convenience

Ensure that you are one step ahead of breakdowns via maintenance indicators and automated diagnostics, or let us handle your maintenance via ASSA ABLOY Entrance Systems' tailored maintenance programs.

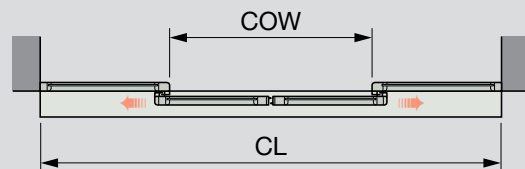
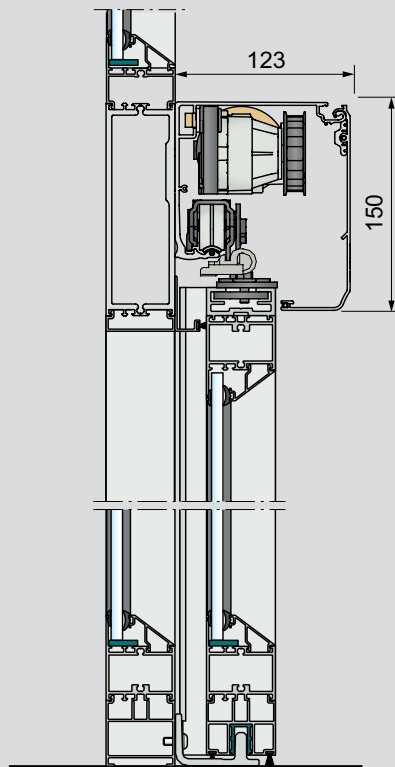

Bi-parting

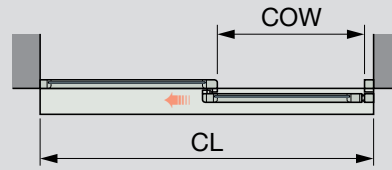

Left opening

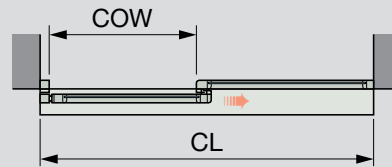

Right opening

COW = Clear opening width
CL = Cover length

Universal and adaptable

The Besam SL500 series can be tailored to your technical requirements, but also to your budget. Its modular features ensure state-of-the-art versatility and upgrades. Together with our extensive range of different door systems, the operator allows you to create an appealing entrance that perfectly matches your business and traffic flow.

Models

Besam SL500-2 - Two leaves, bi-parting, with or without break-out

Besam SL500-R/L - One leaf, single-slide, right or left-opening, with or without break-out

Standard equipment

Cover: clear anodized aluminium

Support beam with transmission

Electronic control unit with plug-in connections and power supply

Accessories and options

Cover: Other anodizing options or painted in RAL colours

Door adaptor for doors up to 65 mm thick from other suppliers

Traffic-controlled opening width

Synchronizing of two operators

Operation mode selectors

Electronic emergency opening or closing unit

Break-out doors

Emergency button

ASSA ABLOY motion and presence sensors

Electrical locking devices

Interlocking between operators

Key switch

Besam automatic door systems

This equipment should be installed, regularly inspected, maintained and serviced by trained and authorized personnel. Preventive maintenance plans are highly recommended for a proper and safe operation. Talk to your ASSA ABLOY Entrance Systems representative to learn more about our service offering!