

# High Performance Door Albany RR300 Food

ASSA ABLOY

ASSA ABLOY Entrance Systems

The global leader in  
door opening solutions



# Albany RR300 Food

Particularly suitable for:

- Access to production, washing and storage areas
- Entry/Exit to transport areas
- Protection against contamination and rises/falls in temperature
- Separation of sterile and non-sterile areas
- Protection against pests

## DOOR MATERIAL

The entire door (side frame, motor and top roll cover, bottom profile) consists of V2A stainless steel.

## DOOR CURTAIN

The door has a curtain of clear PVC with vertical blue fabric stripes. Other versions with fabric reinforcement stripes in a wide variety of RAL colours may be delivered on request. A FDA-tested PVC curtain with white reinforcement stripes is available on request.



## MANUAL ACTIVATION

In the event of interruption or a power failure, the door can be opened via an emergency crank handle. As an option, the door can open automatically by pulling the Bowden lever and lifting the door up. The Bowden lever releases the brake and the counterbalance system pulls the door up.

## HINGED SIDE FRAMES

The side frames may be opened easily for the cleaning and disinfection of the internal area.



## BOTTOM PROFILE

A gutter on the Bottom profile prevents liquids from the curtain from dripping into the clear opening.

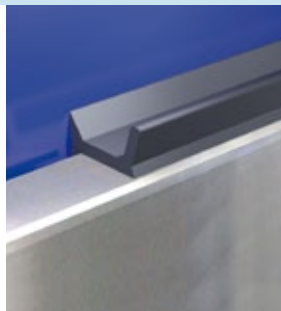

## SAFETY FEATURES

As standard the door is equipped with an electrical safety contact edge and a door line photocell. Optional a pre-running safety photocell may be installed instead of an electrical safety contact edge.





### MOTOR AND TOP ROLL COVER

As an option the door can be equipped with a stainless steel motor and barrel cover. For cleaning purposes the barrel cover is always hinged.



### MOTOR POSITION

The drive unit is a geared brake motor. It is positioned by choice on the right or the left.

### FREQUENCY CONVERTER CONTROL

Albany MCC technology is applied as a control system. The user interface has a graphical display and comfortable foil keyboard. Extensive diagnostic and troubleshooting messages can be read directly from the display.



### OPEN SIDE PROFILE

The side supports are open at the bottom, so that the cleaning water can run off without problems and no debris can remain.



# High Performance Door Albany RR300 Food

Food processing represents a working environment which places extraordinarily high and specific demands on the operating resources deployed within it. In this way, a high degree of hygiene is required in these areas, which thus requires a high degree of resistance by deployed operating resources to aggressive cleaning materials. Doors in these areas must be easy to clean and disinfect and must be insensitive to cleaning agents, as well as preventing the penetration of dirt. In many areas, doors must be opened rapidly and closed again at all times, e.g. in order to maintain a constant room temperature. The components used, such as side supports and stainless steel panels, door curtains suitable for food with large exposed surfaces and the safety equipment of the doors, ensure trouble-free operation in food and hygienic areas. For these areas, Albany has developed the RR300 Food door. It is distinguished by very good cleanability. The door has been developed taking into account rules and regulations from the area of food processing machinery.

## ADVANTAGES OF THE ALBANY RR300 FOOD HIGH PERFORMANCE DOOR

- Best suited to passages and for closing off hygienic areas in the food processing industry.
- Execution in stainless steel
- Fast opening and closing ensure constant temperature
- Smooth, easily cleaned surface
- Hinged side frames for easy and thorough cleaning (optional)
- Integrated cable routing ensures a smooth total surface area
- Space-saving construction
- A gutter on the bottom profile prevents liquids from the curtain from dripping into the clear opening.
- Hinged top roll cover with a slant
- Curtains FDA-tested (optional)
- Liquids can completely run off the side frames
- Tight sealing (mouse proof)
- Counterbalancing through the stainless steel counterweight (optional)

## DOOR DESIGN

The entire door, side frames, top roll and motor cover and the bottom profile are made of V2A stainless steel.

## DOOR CURTAIN

The door has a curtain of clear PVC with with vertical blue fabric reinforcement stripes. A wide range of RAL colours of the reinforcement stripes are available on request. As option a FDA-tested PVC curtain with white reinforcement stripes are available.

## DRIVE UNIT

The drive unit is a geared brake motor. It may be fitted on the right or left.

## CONTROL SYSTEM

An Albany MCC frequency converter is available as a control.

## MANUAL ACTIVATION

In the event of interruption or a power failure, the door can be opened via an emergency crank handle. As an option, the door can open automatically by pulling the Bowden lever and lifting the door up. The Bowden lever releases the brake and the counterbalance system pulls the door up.

## SAFETY DEVICES

The door complies with the provisions of the German Workplace Ordinance, the German Accident Prevention Ordinance (UVV), the harmonised CE directives and the EN 13241-1 product standard.

## INDICATION OF RISK

The door safety devices are designed for the normal use of power-operated doors in accordance with the harmonised CE directives. In addition, aggravated environmental conditions may affect the proper use of doors in food processing industries. In such situations, we recommend that you consult our local sales engineers for expert advice on specific situations.

## TECHNICAL DATA

Operational area	Hygienic areas, food processing industries
Wind resistance	Class 1 – EN 12424
Door dimensions (W min./max.) (H min./max.)	1000 / 4000 mm 1000 / 4000 mm
Opening direction	vertical

### Surface material V2A stainless steel

Side frames	✓
Bottom profile	✓
Top roll cover with slant 6° <sup>0)</sup>	•
Motor cover with slant 30° <sup>0)</sup>	•

### Door curtain

PVC with blue / red reinforcement stripes	✓
PVC with coloured fabric stripes	•
PVC with white reinforcement stripes	•

### Control / Drive unit

Drive unit	electric
Motor power	0,75 kW
Control system	Albany MCC
Dimensions control box	• 500 x 500 x 210 mm
Adjustable additional opening height	✓
Potential free contacts max. 250 V	•
Fuse protection <sup>1)</sup>	10 A <sup>1)</sup>
Control voltage	24 V DC
Protection degree	IP 55
3L / (N) / PE 380 / 400 / 440 / 480 V; 50 / 60 Hz	✓ <sup>2)</sup>
Open/close speed up to max.	2,2 / 1,0 m/s

### Safety

Electrical safety contact edge	✓
Door line photocell	✓
Pre-running safety photocell	•
Counterbalance system with self-opening by bowden lever	•
Knock-out capability with pre-running safety photocell	•
Manual activation with an emergency crank handle	✓

### Notifications

Traffic light function	•
Error message Albany MCC	✓ plain text

- Option
- ✓ Standard

0) For doors with a height of ≤ 2.5 m, a top roll and a motor cover is required in order to comply with the requirements of standard

1) 10 A preferred, 16 A max.

2) Transformer necessary for 220/230/500 V

# General Drawing Albany RR300 Food

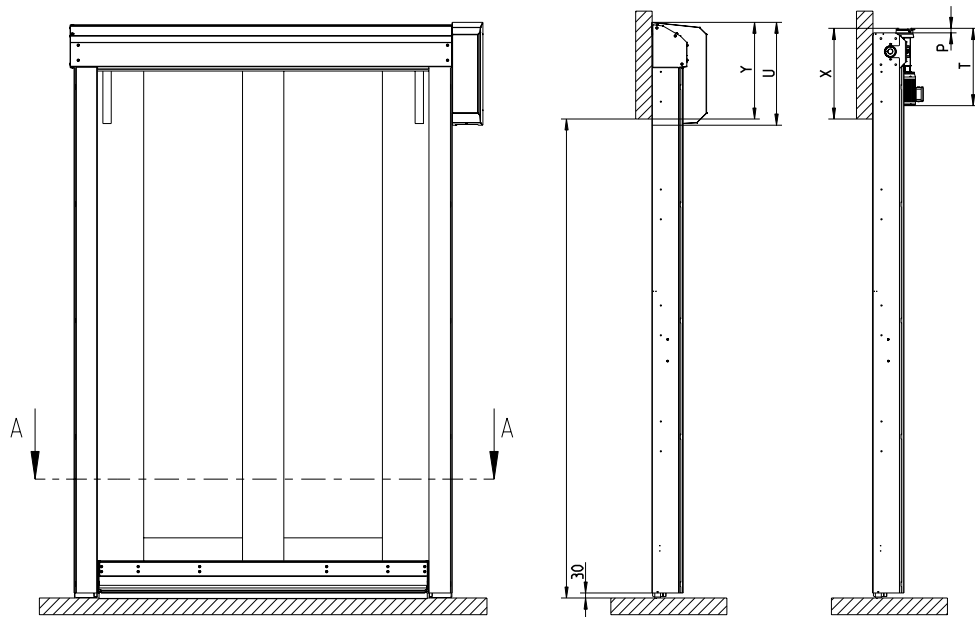

9300R0004/0  
Date: 08.06.2011

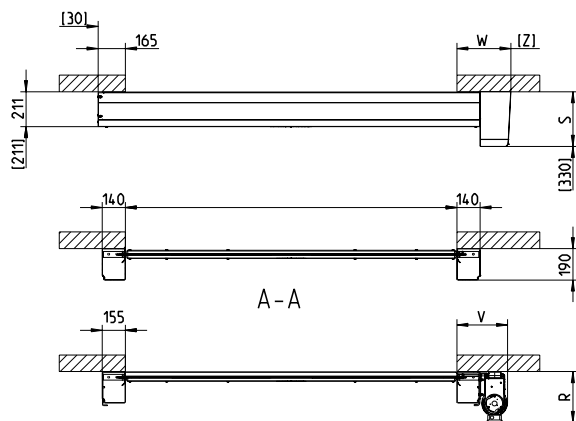

Available size		
	DW (B)	DH (H)
min. (mm)	1000	1000
max. (mm)	4000	4000

Without a motor cover	
	Albany MCC (mm)
X	440
V	305
R	315
T	550
P	45

With a motor cover	
	Stainless steel (mm)
Y	470
W	330
S	330
U	643
Z	110

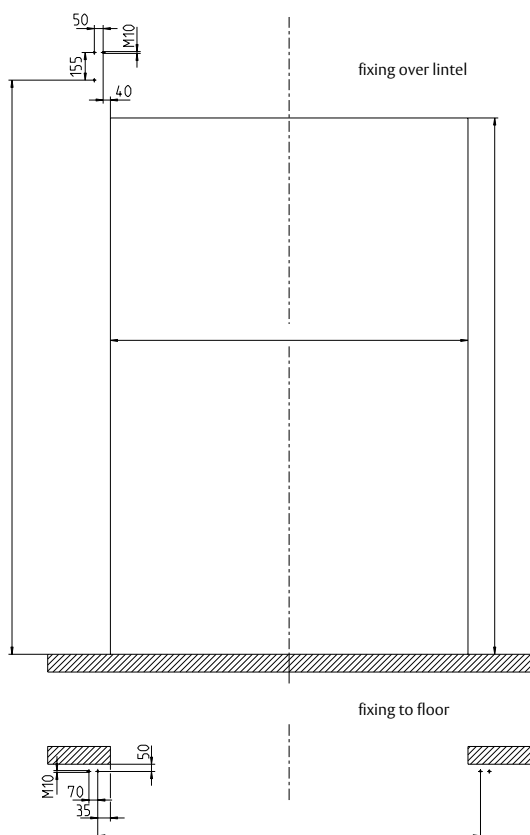

Albany MCC		
Opening speed	max. (m/s)	2,2
Closing speed	max. (m/s)	1,0
Dimensions WxHxD	max. (mm)	500 x 500 x 210

[ ] = Space needed for installation

9200R0003/0  
Date: 29.09.2010

ASSA ABLOY Entrance Systems is the world's most comprehensive supplier of entrance automation solutions. With our globally recognized product brands Besam, Crawford, Megadoor and Albany, we offer products and services dedicated to satisfying end-user needs for safe, secure, convenient and sustainable operations. With a holistic approach to the flow of goods and people, we create efficient solutions for each business, with the best possible balance of cost, quality and lifetime performance. ASSA ABLOY Entrance Systems is a division within ASSA ABLOY.

[www.assaabloyentrance.com](http://www.assaabloyentrance.com)



**ASSA ABLOY Entrance Systems**  
**High Performance Door Solutions**

[info.albany@assaabloy.com](mailto:info.albany@assaabloy.com)  
[www.assaabloyentrance.com](http://www.assaabloyentrance.com)

