

# Automatic Door System Besam Three- and Four-Wing RD3 and RD4

ASSA ABLOY

ASSA ABLOY Entrance Systems

The global leader in  
door opening solutions



Besam's 3- and 4-wing compact revolving doors RD3/RD4 help to maintain a comfortable indoor climate and at the same time save energy costs

### Sustainable Entrances

Besam revolving doors can reduce the amount of energy needed to heat or cool a building, resulting in optimal energy savings and smaller carbon footprint. Regular maintenance, additional sensors and add-on products can further increase saving capabilities while prolonging the equipment's life.

### Technical specifications

Power supply	230 V, 50 Hz, mains fuse max 10 A, 100-120 V, 50/60 Hz, mains fuse max 16 A
Power consumption	200W /30W resting
Lighting LED 5W	30W /60W

### Comfort, safety and economy

The Besam RD3/RD4 combines the advantages of a revolving door for the internal environment with the safety and security of an automatic door, at a cost more typically associated with manual revolving doors.

The larger diameters in the Besam RD3/RD4 range are suitable for people carrying luggage, for example, at a hotel entrance. The smaller diameters provide an entrance door suitable for moderate pedestrian traffic.

### Safety the highest priority

The door range combines safety and practicality with the safety of the user as its number one priority. To prevent injury, the drum edges are equipped with soft safety edges.

### Safety features

- If an obstacle prohibits the rotation of the door (the resistance is higher than the pre-set value) the rotation will cease
- Compressible vertical safety switches placed on the drum edges
- Speed control
- Emergency break-out system (optional)



Frame system



Slim system with shaft



Slim system without shaft

### Design

The Besam RD3/RD4 can be ordered in several different configurations depending on the customer's needs. There are two options for the outer drum and three different types of door leaves to choose from, each with a different look and feel. Depending on the rail and panel options selected, the door can produce varying degrees of interior privacy.

The Besam RD3/RD4 is available in various sizes with flexible internal height and fascia height to match any building.

All of our revolving door systems are made from Besam-designed aluminium profiles which can be anodized, powder-coated or stainless steel-clad. The drive mechanism is fitted on a frame above the laminated ceiling. The drive shaft bearing is fixed to the finished floor. Brushes seal the door tightly. The doors are designed to be placed and fixed directly onto the finished floor surface. No special foundations are required. For unfinished floors, a ground ring is available as an option.

### CDC Control system

This unique and state-of-the-art control system was developed by Besam specifically for use with its products, and the result is a fully integrated entrance solution with no compromise in design or function. The system ensures lowest operating/maintenance cost, highest safety and best availability.

During installation:

- Automatic system check up
- Fast and safe adjustments of all safety zones and speed settings
- Short installation time

During operation:

- The Besam RD3/RD4 is equipped with a program selector with access codes to operate the door
- If equipped with a modem or connected directly to a computer, the Besam RD3/RD4 can be remotely operated without any special software
- Self-checking of safety systems
- Real-time clock with programmable modes/functions

- Automatic indication of service intervals
- Performance measurements
- Short stopping distances
- Light switches off automatically in locked position.

During service:

- Automatic event log showing the 600 latest events
- Automatic diagnostics
- Connected to Besam Service by phone/modem
- Easy access by program selector or std. PC terminal
- Remote fault finding
- Minimum down time

### Speed control

The maximum rotation speed is factory pre-set, but can be adjusted to suit different applications. The door cannot be manually rotated faster than the pre-set limit.

### Evacuation path

By adding the emergency break-out system, a clear, unimpeded evacuation path through the revolving door can be achieved. The electromechanical release can be integrated with a fire alarm. This release also ensures that the door leaves collapse only when required and not under wind pressure. The break-out system can also be very useful under less dramatic circumstances, for example when bringing long objects through the entrance.

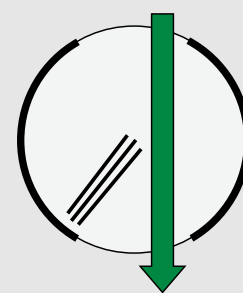

3-wing

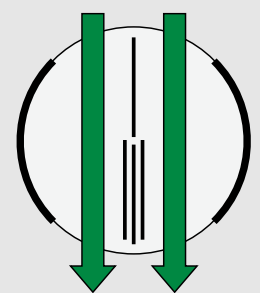

4-wing

Frame system  
with Night closing doors

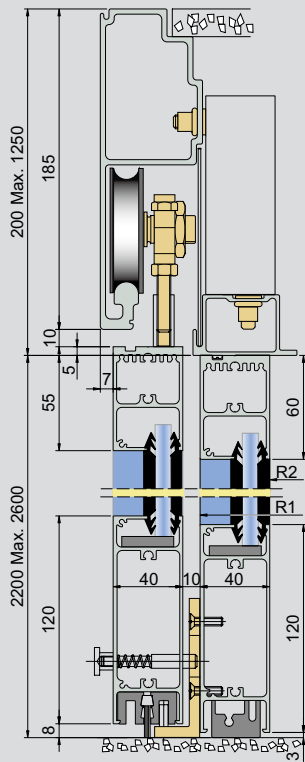

Slim system  
with Night closing doors

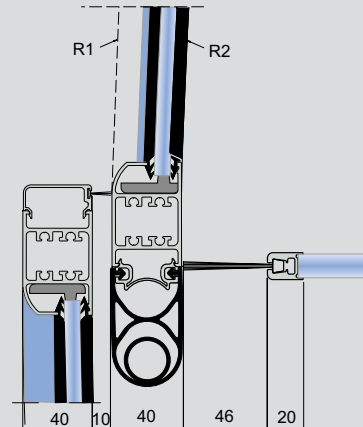
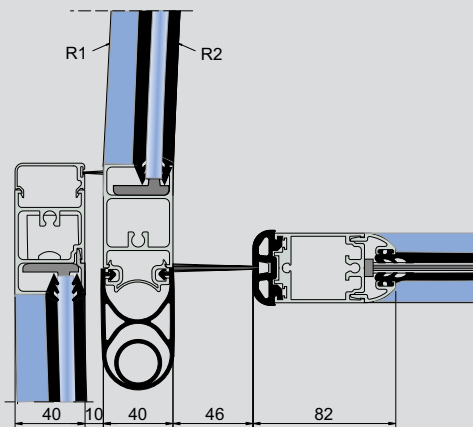
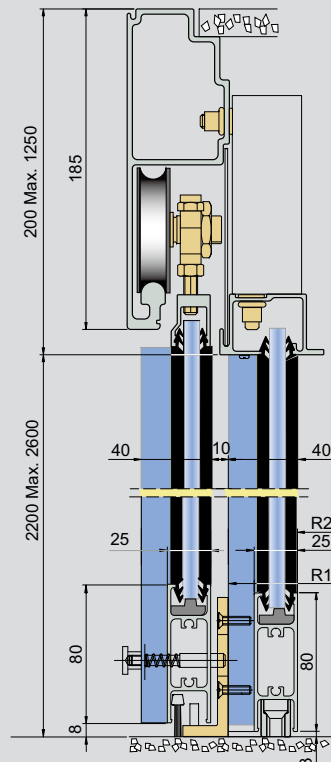

Frame and Slim system can be combined

### Function

Program selector:

- Off: Door is locked if electromechanical lock is fitted
- Auto start: The door stands still. When the door is activated by the inner or outer activation unit or by pushing (Push and Go), the door rotates at normal speed through three compartments and then stops.
- Continuous rotation: The door rotates at low speed. When the door is activated by the inner or outer activation unit, the door rotates at normal speed through three compartments and then returns to low speed.
- Manual override: Forward and reverse
- Normal speed adjustment: Adjustable from 1.5 to 5 rpm
- Low speed (for disabled): 1.5 rpm

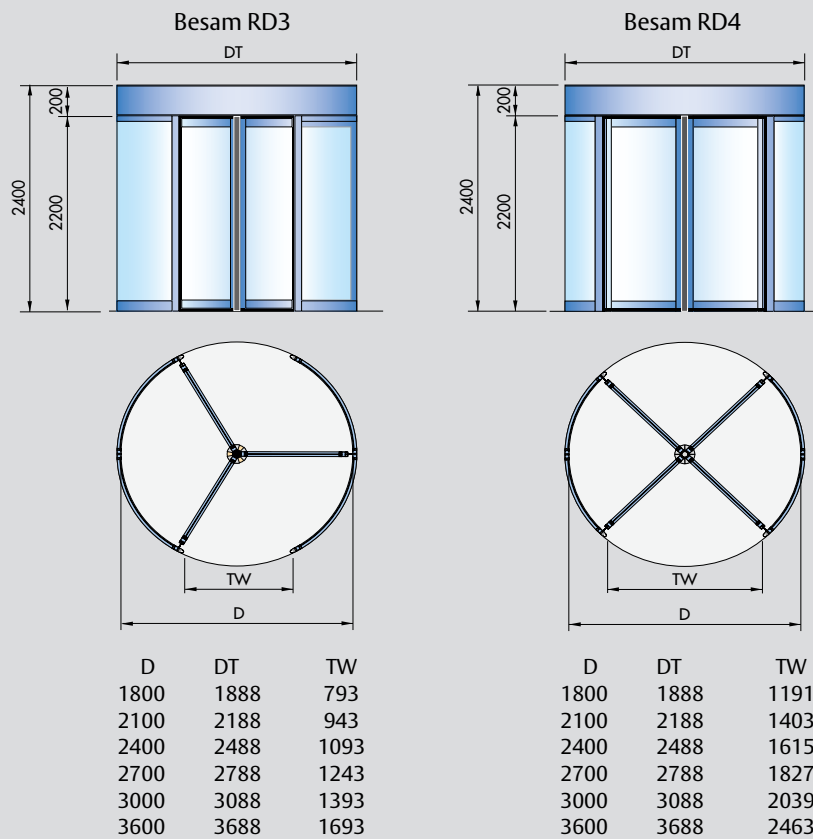

### Standard equipment

Automatic drive
Control unit built-in behind the fascia above the inside entrance
Microprocessor controlled with plug-in modules and LED status lights
Speed control
Vertical safety switches
Glass wall: 4 + 4 mm clear laminated (Frame/Slim)
Glass door leaves: - 3 + 3 mm laminated (Frame) - 6 + 6 mm laminated and tempered (Slim)
Other types of glass available
Door sections made from aluminium profiles
Ceiling made from white laminated panels
Dust protection roof made from white laminated panels
Emergency stop

### Accessories and Options

Besam activators
Powder-coated finish (RAL colours)
Anodizing, clear or bronze
Stainless steel cladding
Electromechanical lock
Night closing doors (NCD), manual or automatic
Mechanical lock on NCD
Fascia, non-standard height (200 - 1250 mm)
Internal height non-standard (2100 - 2600 mm)
Sheet metal sandwich panel instead of glass (Frame only)
Access control program device
Modem for remote operation
Ground ring for unfinished floor
Disabled push button
Various options for ceiling surface
Spotlights/Downlights
Water-resistant cover
Rotation brake
Emergency break-out system
Midrails on door leaves and/or outer walls
Additional safety on rotating part

This equipment should be installed, regularly inspected, maintained and serviced by trained and authorized personnel. Preventive maintenance plans are highly recommended for a proper and safe operation. Talk to your ASSA ABLOY Entrance Systems representative to learn more about our service offering!